

# OPEN-OUT

# Top-hung

W<sub>smin</sub>. 756.68 - H<sub>smin</sub>. 450

W<sub>smin</sub>. 29.79 - H<sub>smin</sub>. 17.72

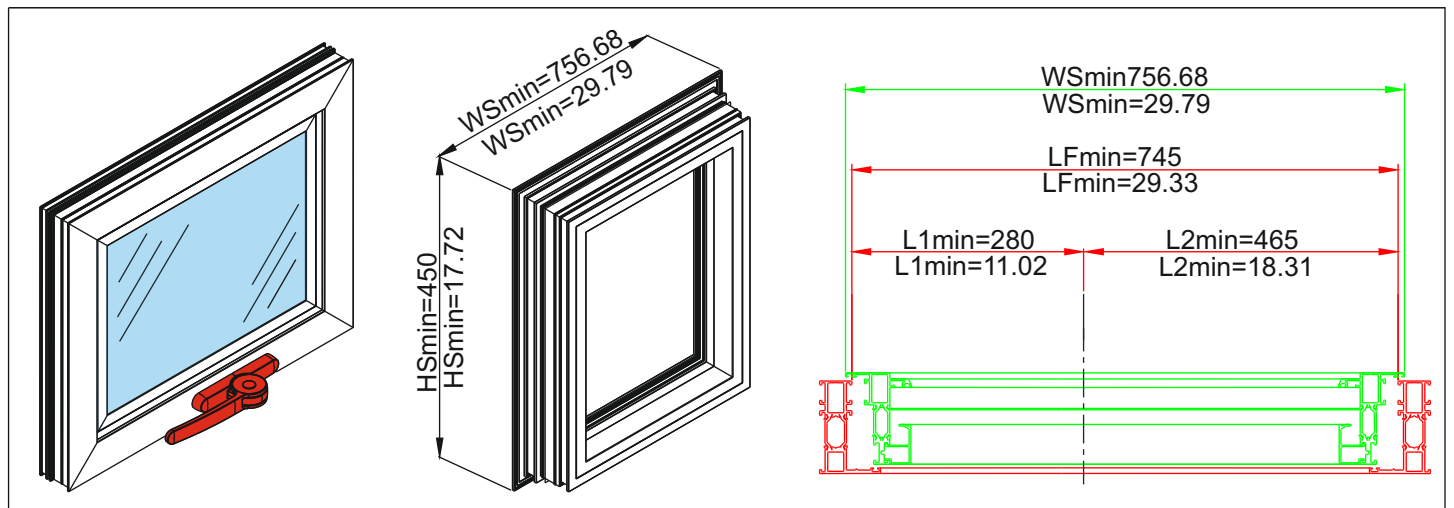
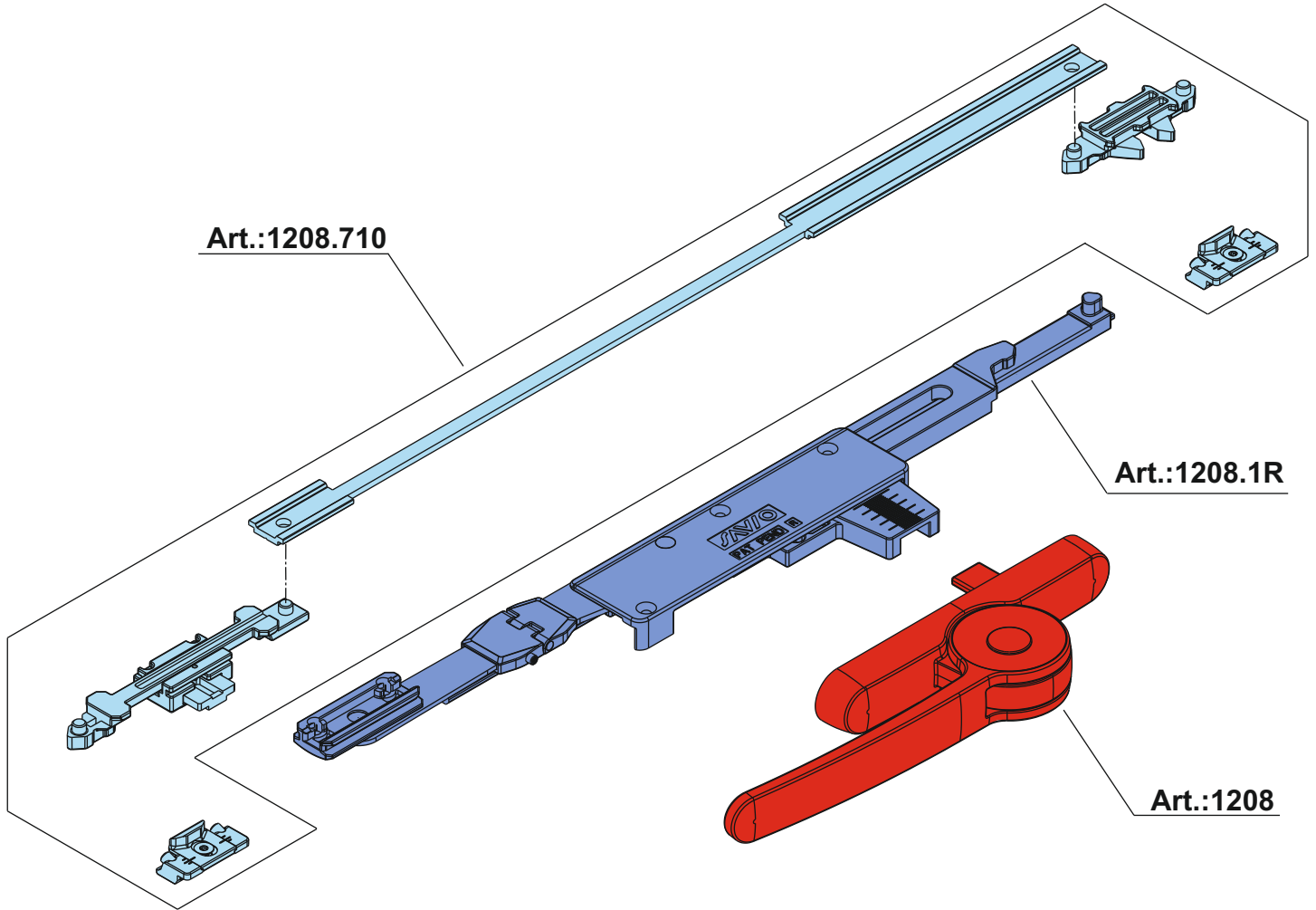

## LAVORAZIONE TELAIO - FRAME MACHINING

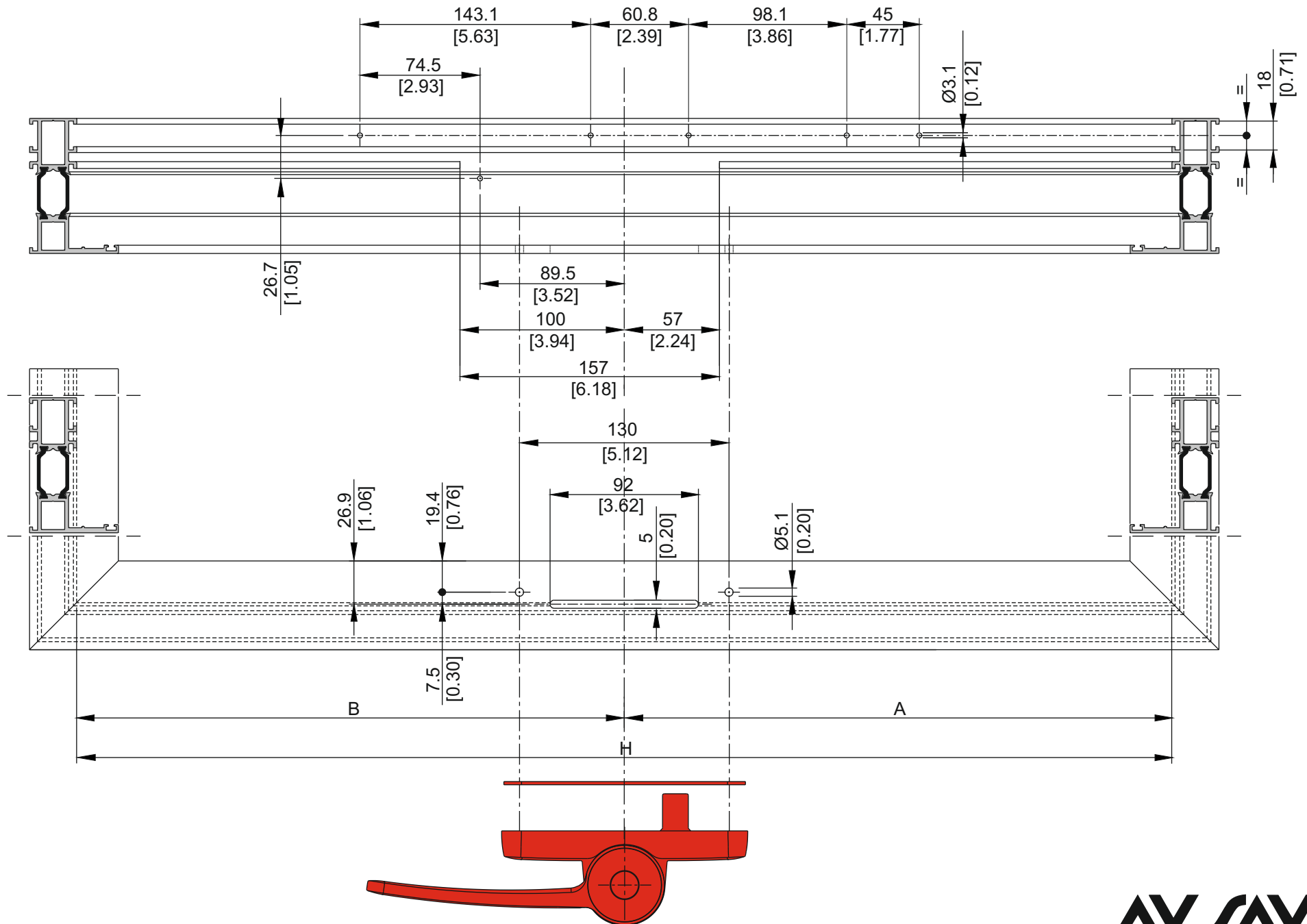

## LAVORAZIONE ANTA MOBILE MOVING LEAF MACHINING

- scantonare negli spigoli
- cut the aluminum in the corner

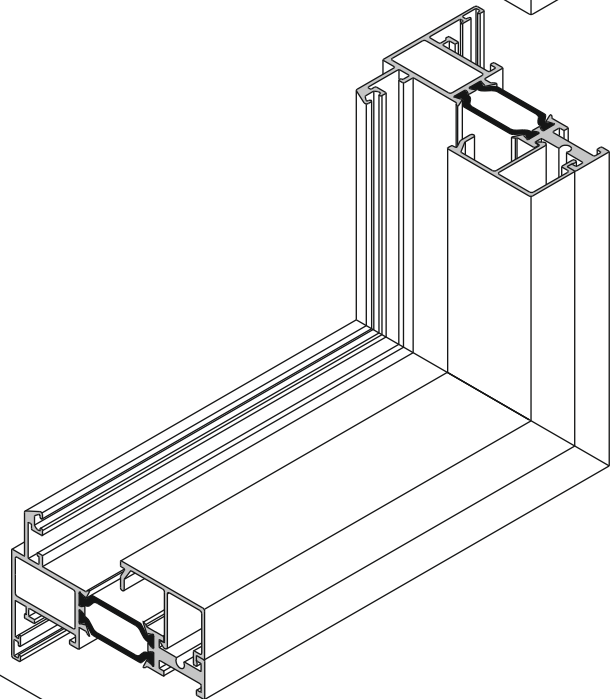
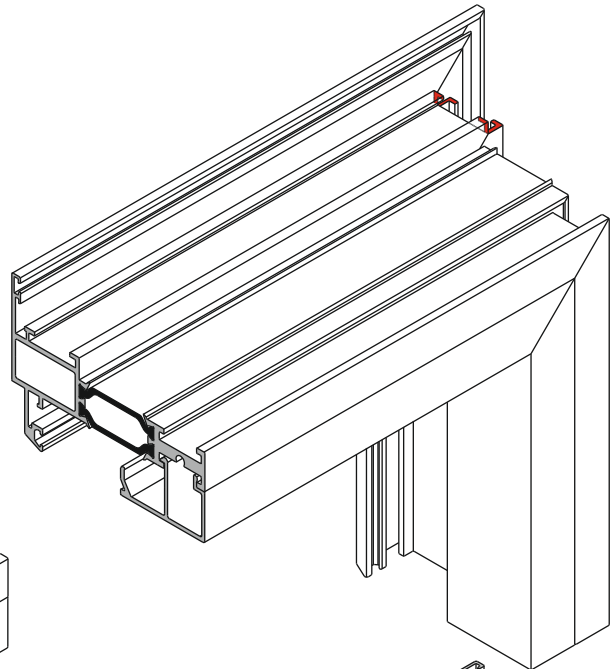
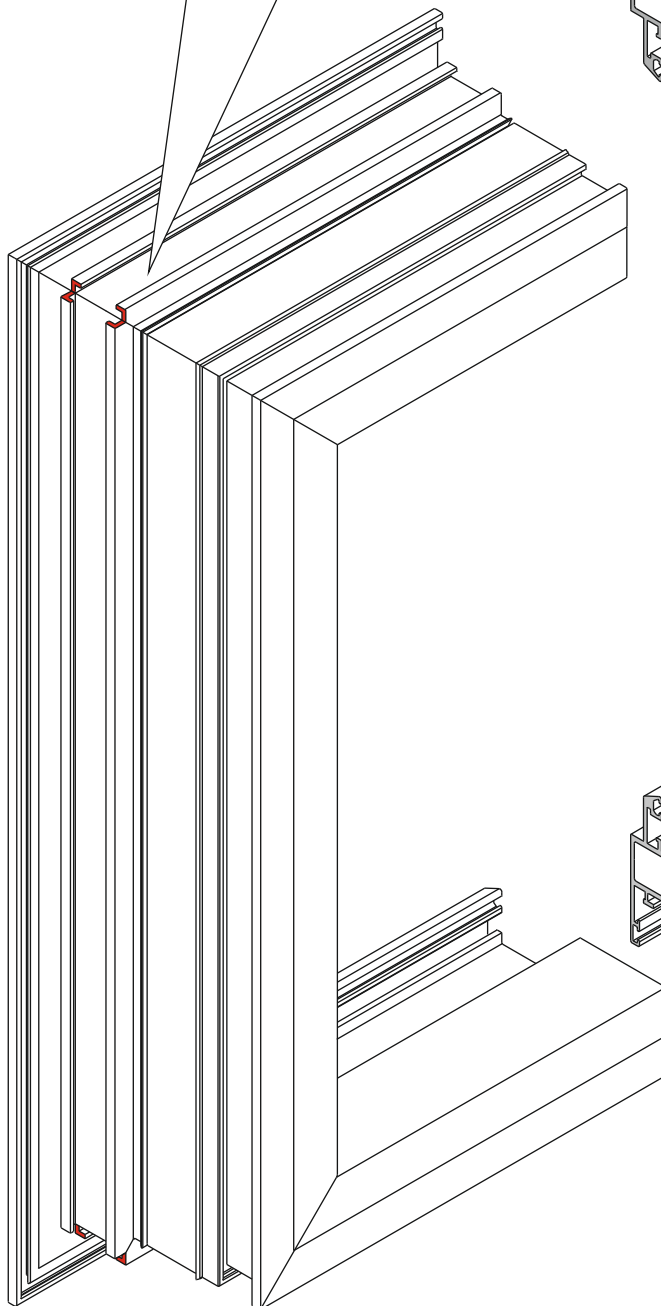
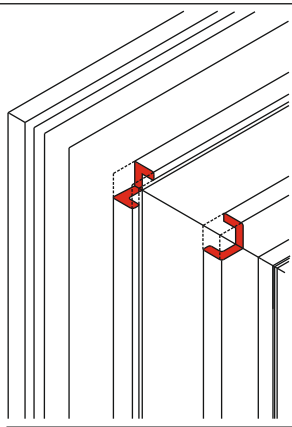

## DIMA DI FORATURA PER TELAIO DRILLING JIG FOR FIXED FRAME

I

Art.:1208.950R

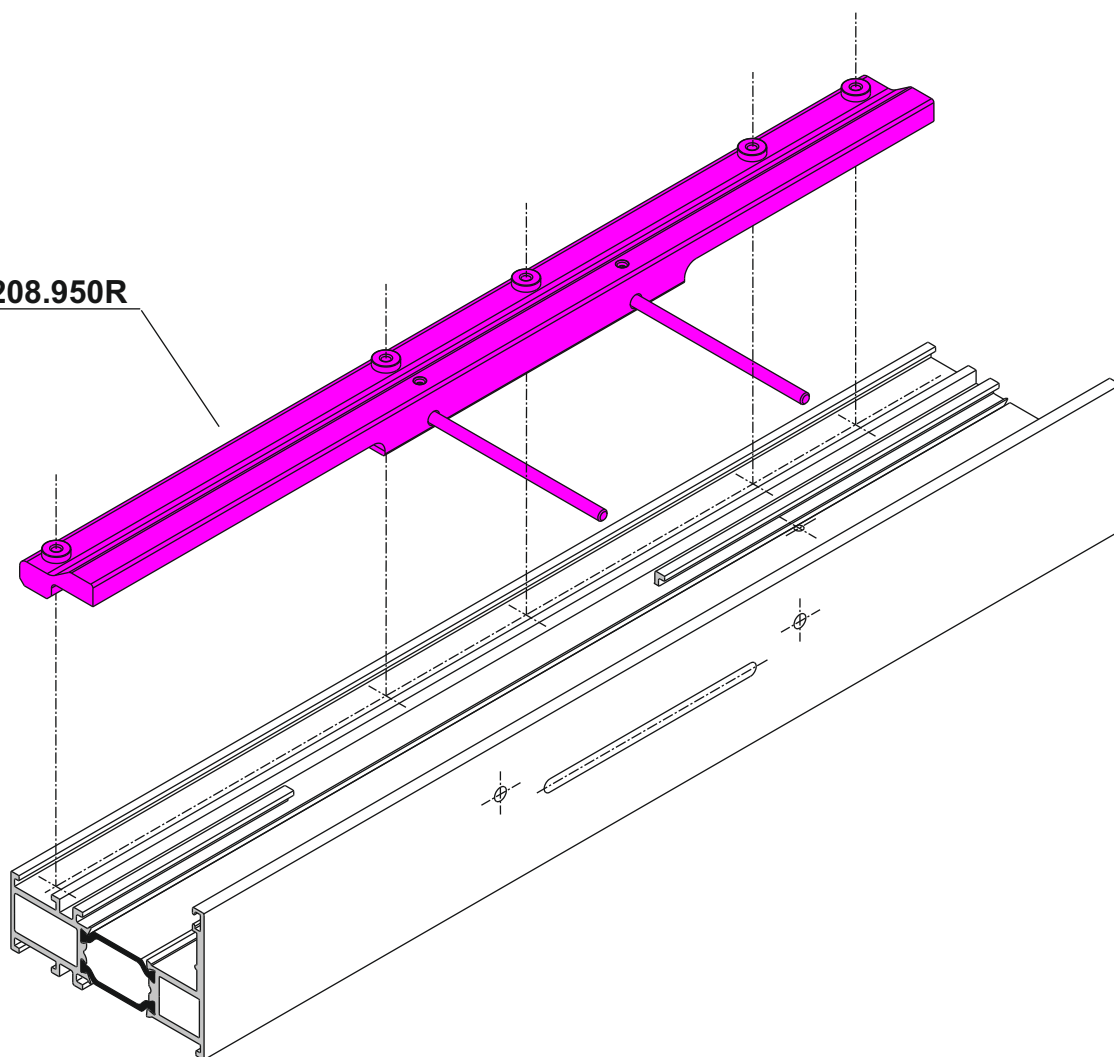

II

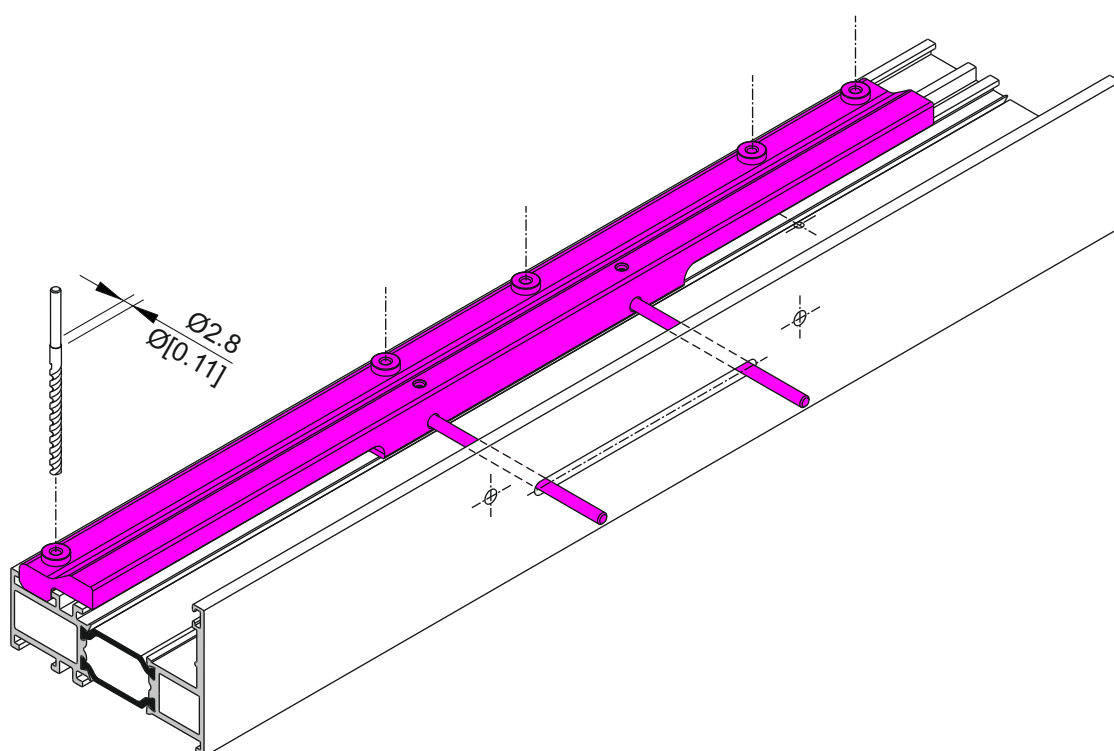

## MONTAGGIO CARIGLIONE HANDLE FITTING

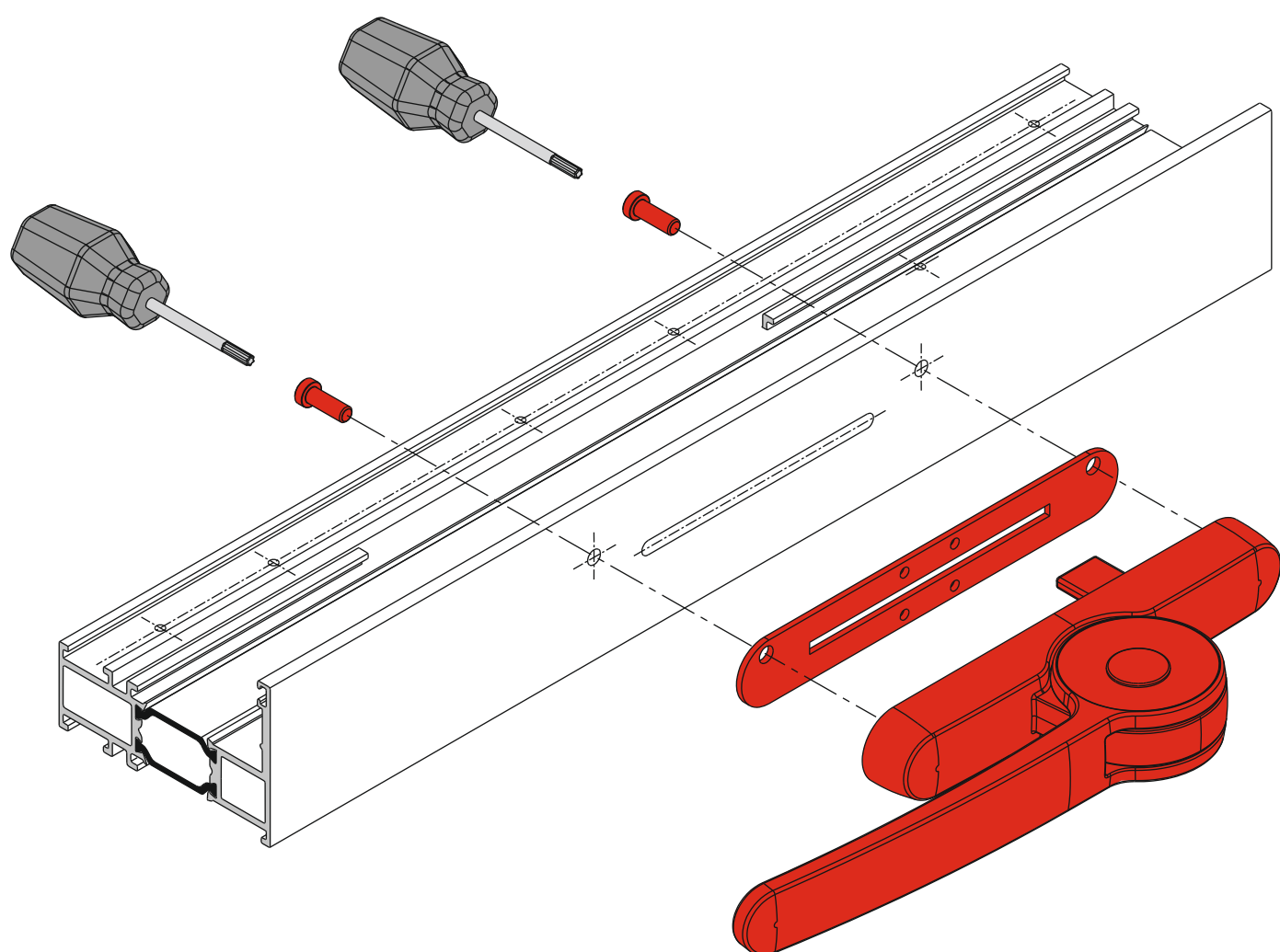

## MONTAGGIO MECCANISMO DI MOVIMENTAZIONE FITTING MOVEMENT MECHANISM

I

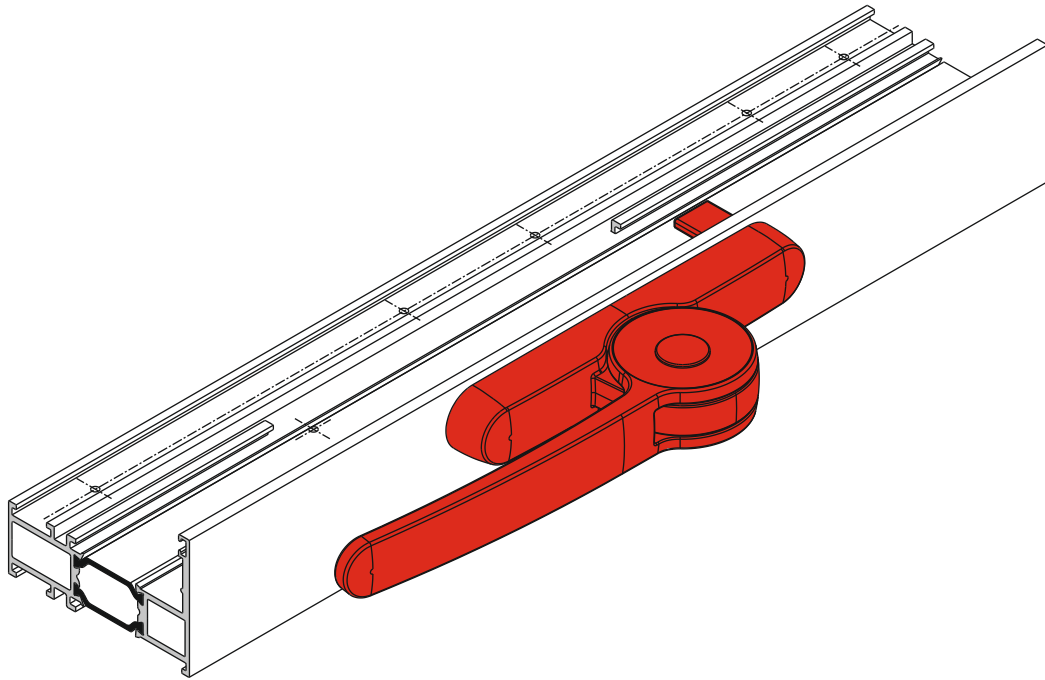

II

Estendere manualmente il braccio del «meccanismo di movimentazione» fino alla sua massima estensione, quindi agganciare il meccanismo «a scatto» sul telaio e fissare il tutto con le 5 viti TORX 3.9x22 in dotazione

Manually extend the arm of the "movement mechanism" up to its maximum extension, and then hook it "click" on the frame and fix it with the 5 Torx screws 3.9x22 supplied

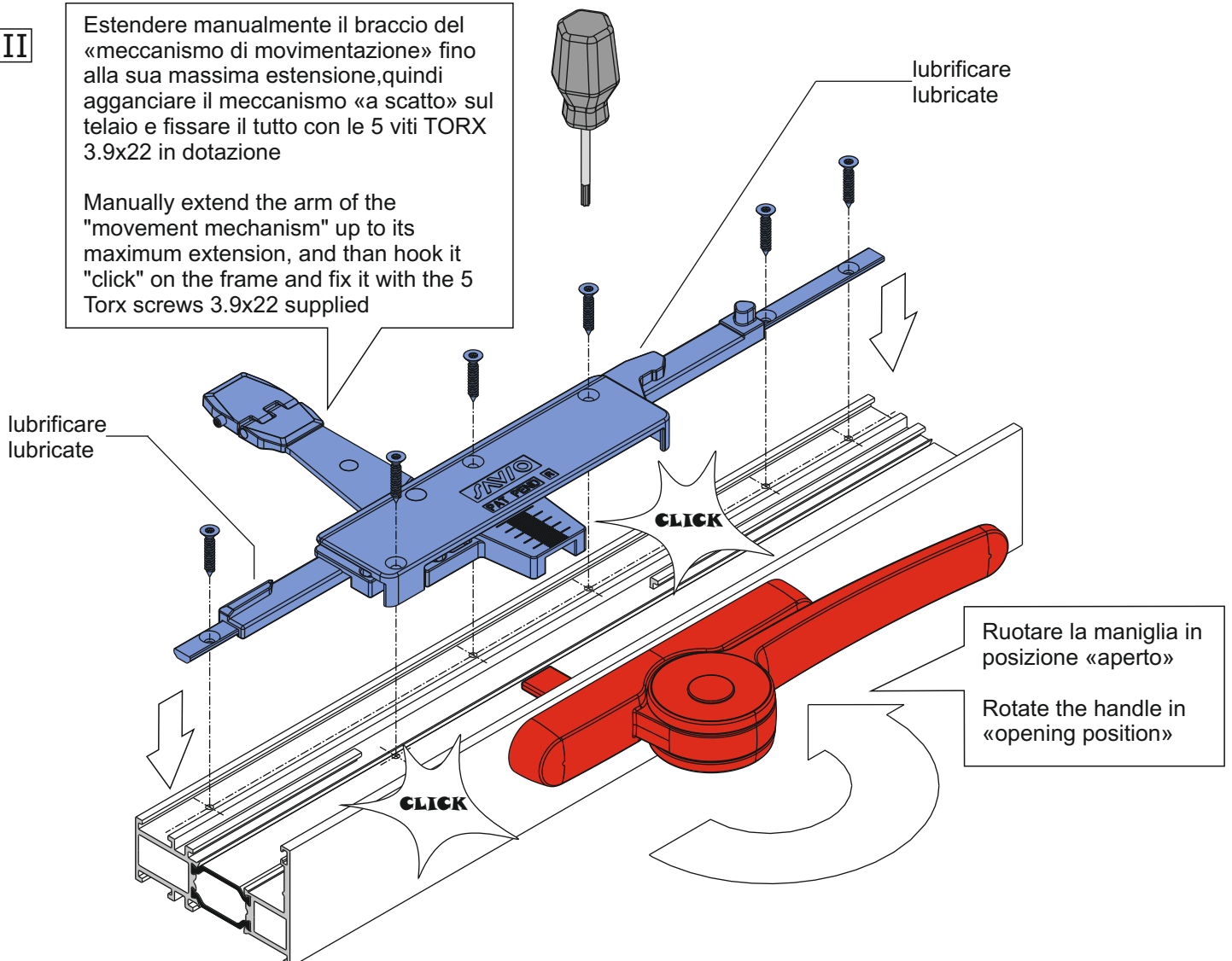

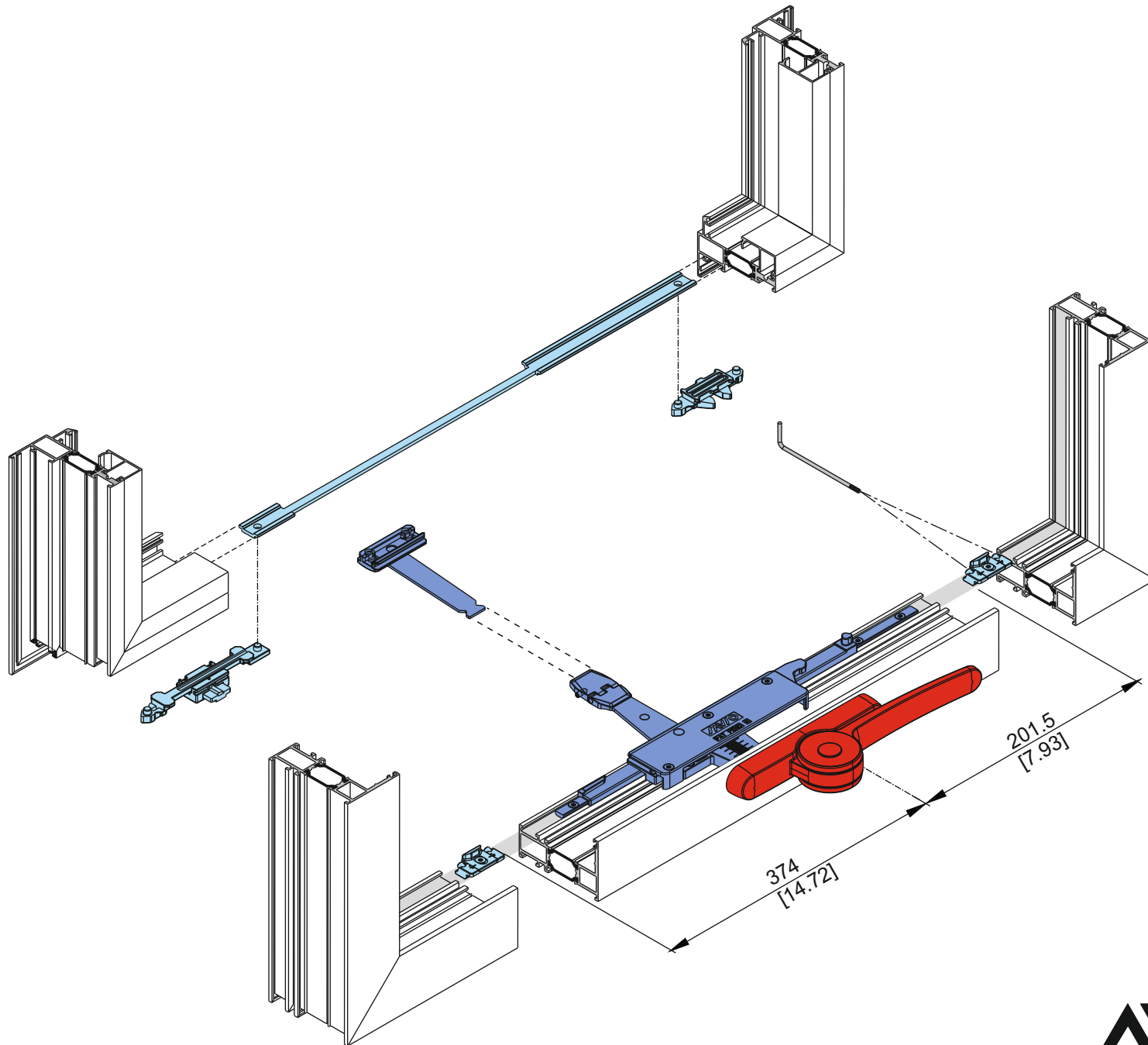

## DIMA DI POSIZIONAMENTO ACCESSORI SU ANTA MOBILE JIG FOR ACCESSORIES POSITIONING ON MOVING LEAF

I

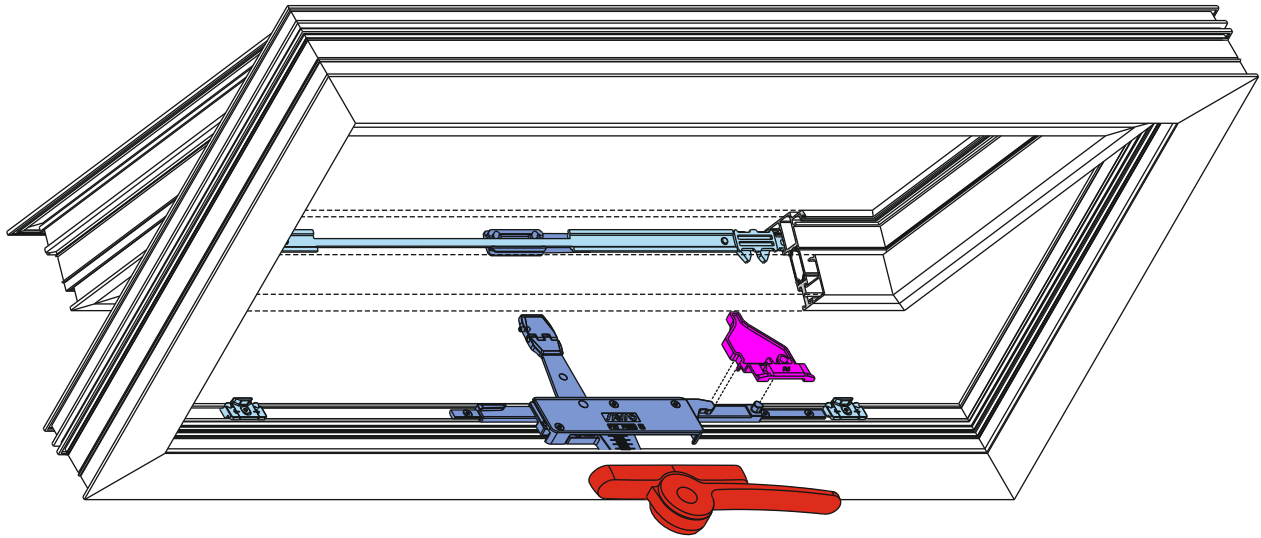

II

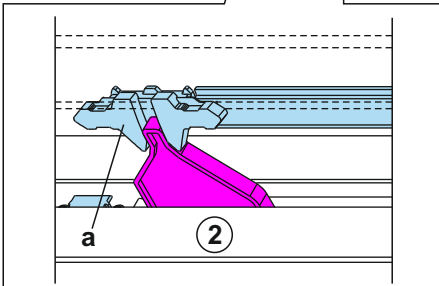
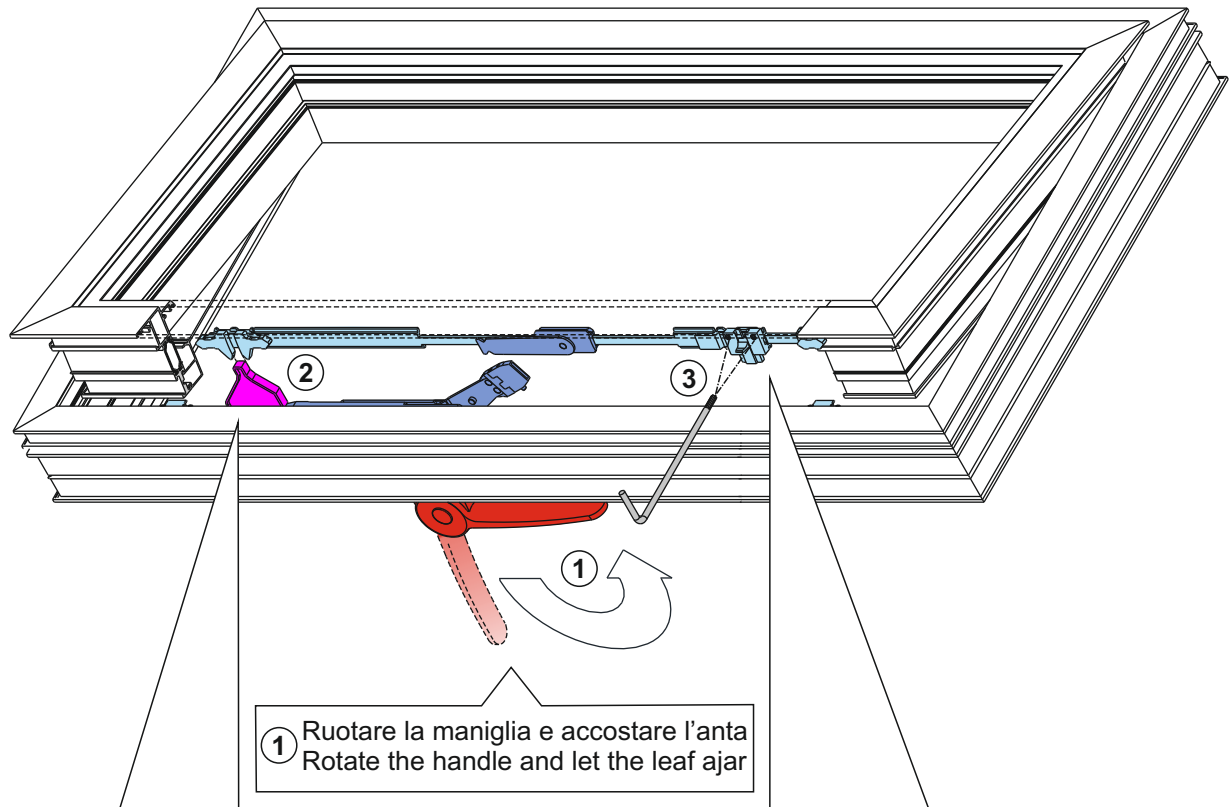

Inserire la forcella «a» nel dentino della dima  
Insert the peak of the jig in the vertical fork «a»

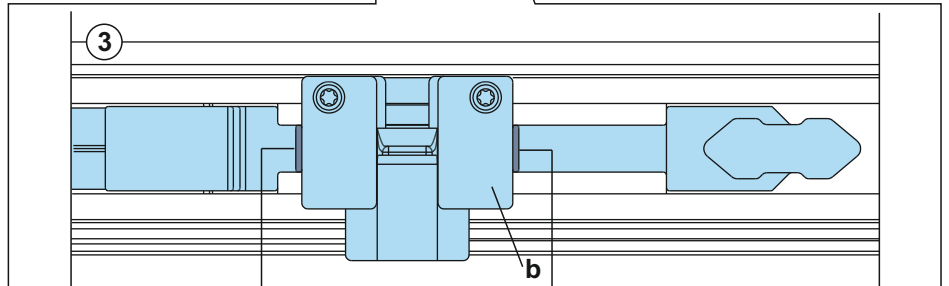

Riferimenti  
Reference marks

Posizionare il particolare «b» tra le tacche di riferimento e serrare i grani di fissaggio.  
Place the particular «b» between the reference marks and tighten the grub-screws.



## POSIZIONAMENTO ACCESSORI SU ANTA MOBILE ACCESSORIES POSITIONING ON MOVING LEAF

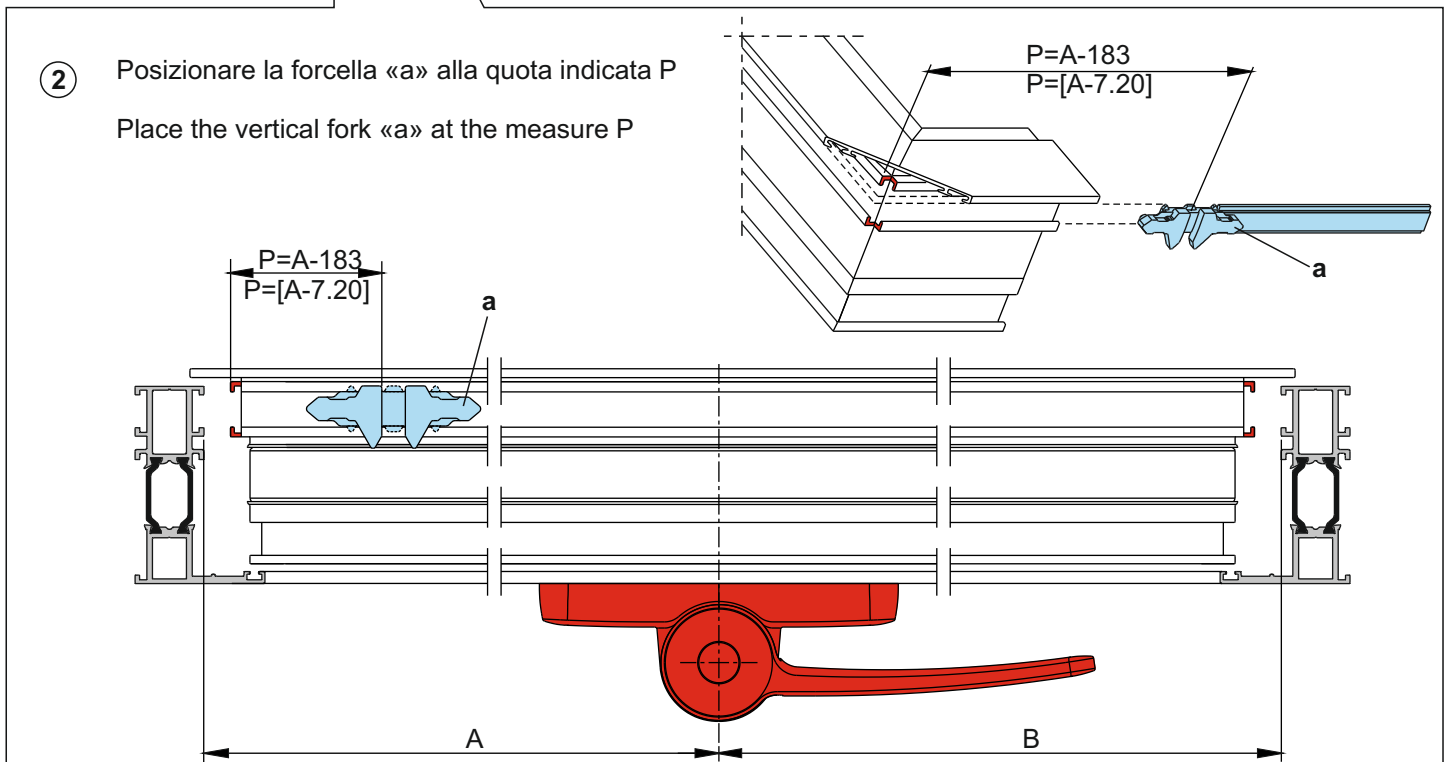
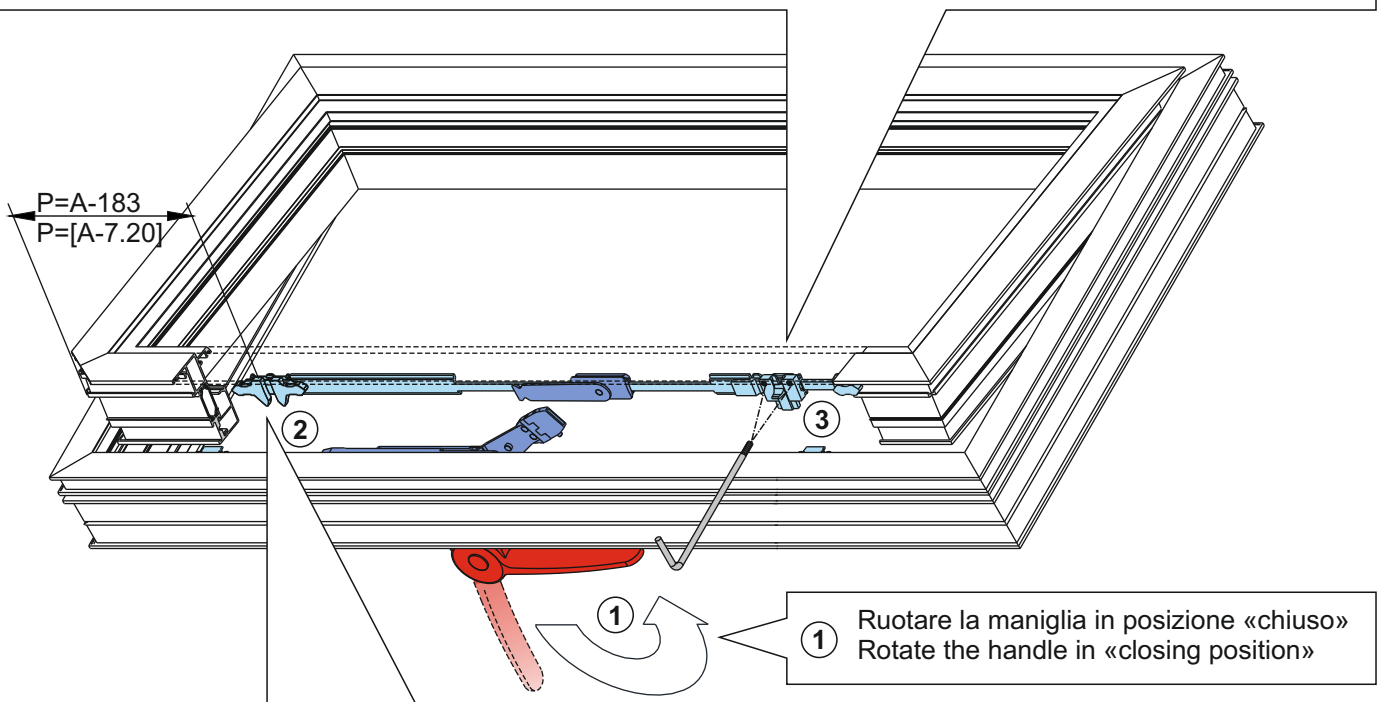
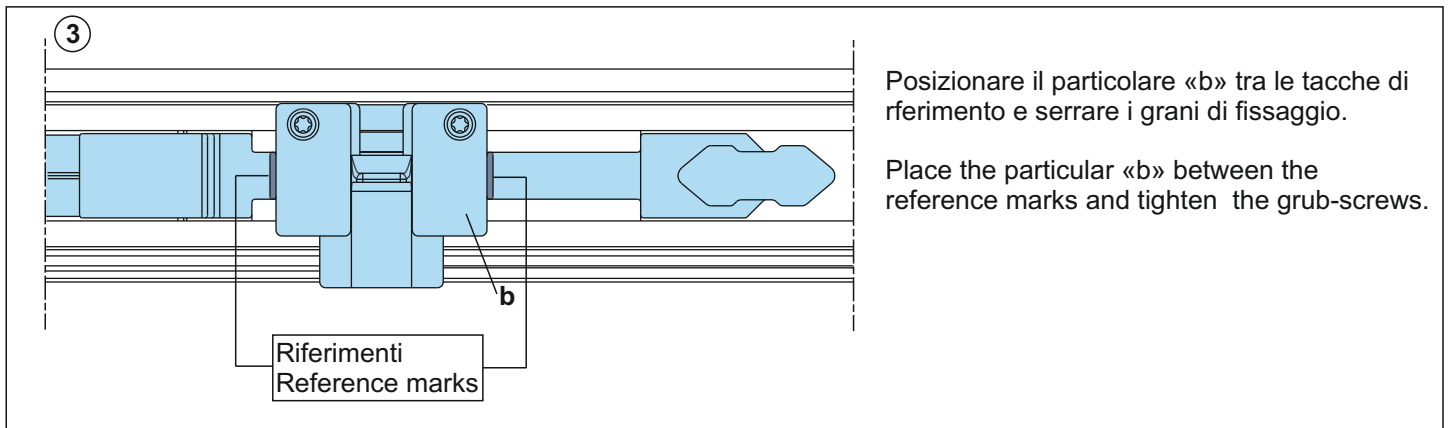

## DIMA DI POSIZIONAMENTO ACCESSORI SU TELAIO FISSO JIG FOR ACCESSORIES POSITIONING ON FIXED FRAME

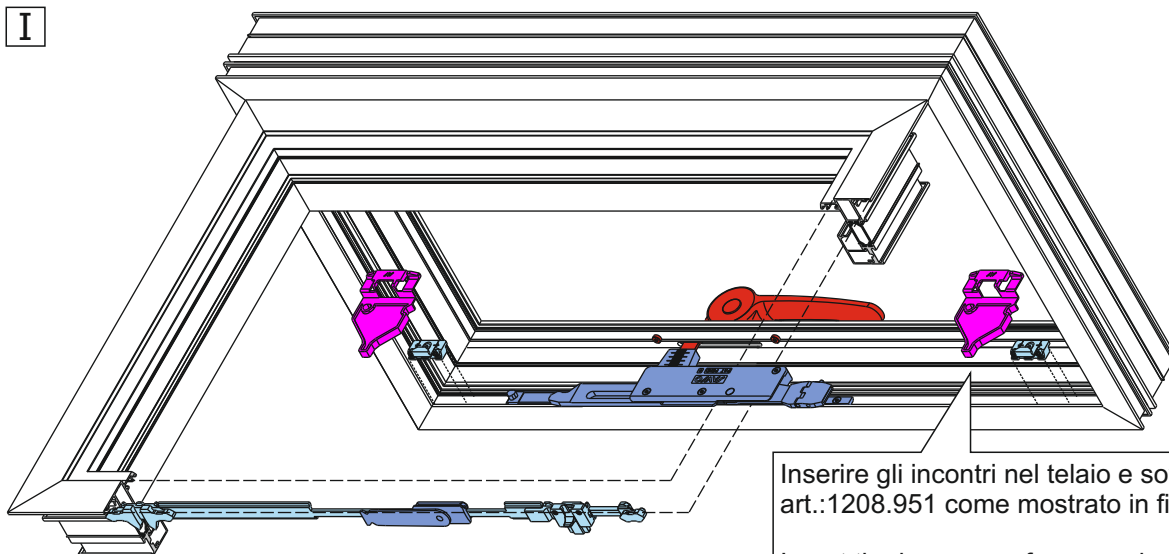

Inserire gli incontri nel telaio e sovrapporre la dima art.:1208.951 come mostrato in figura.

Insert the keeper on frame and overlap on it the jig item:1208.951 as shown

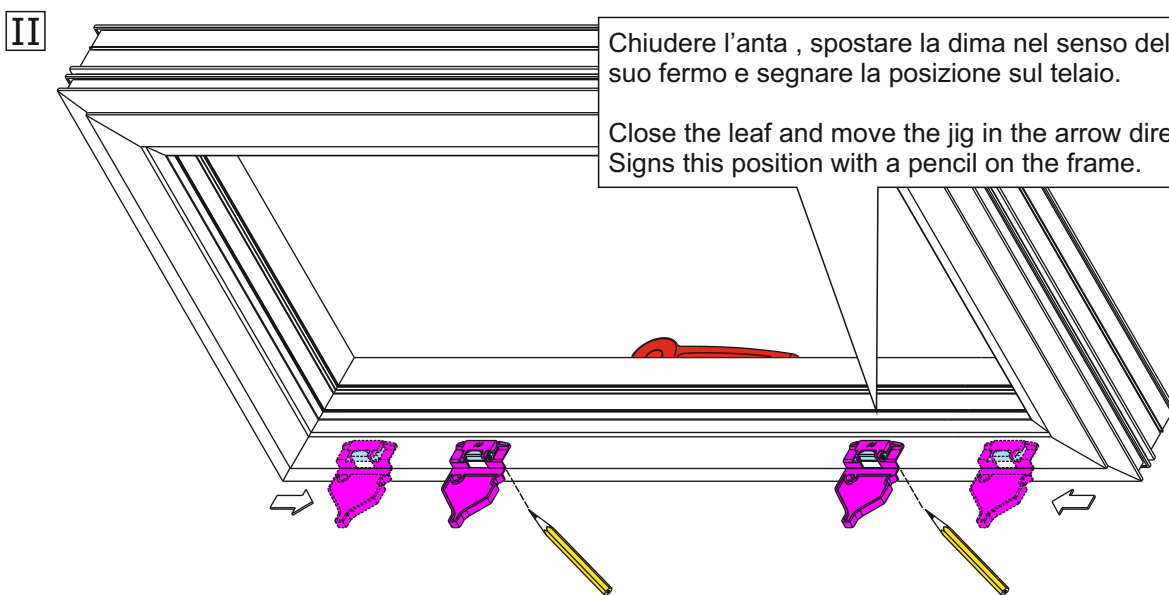

Chiudere l'anta , spostare la dima nel senso della freccia fino al suo fermo e segnare la posizione sul telaio.

Close the leaf and move the jig in the arrow direction until it stops Signs this position with a pencil on the frame.

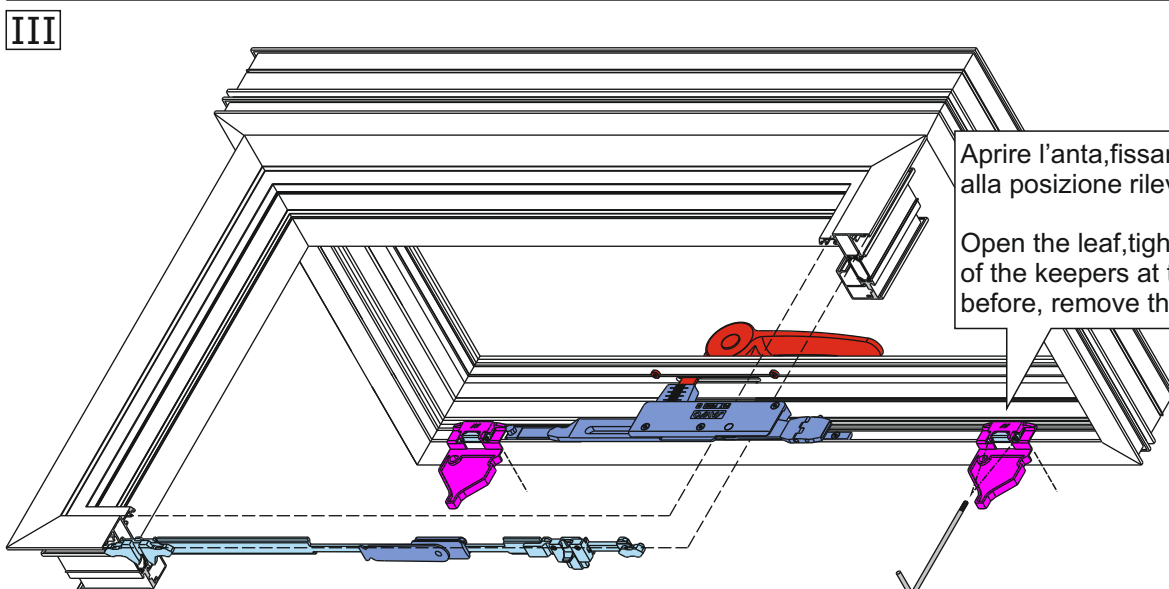

Aprire l'anta, fissare i grani degli incontri alla posizione rilevata, togliere la dima.

Open the leaf, tighten the grub screws of the keepers at the position drawn before, remove the jig

## COLLEGAMENTO ANTA-TELAIO FRAME-SASH CONNECTION

I

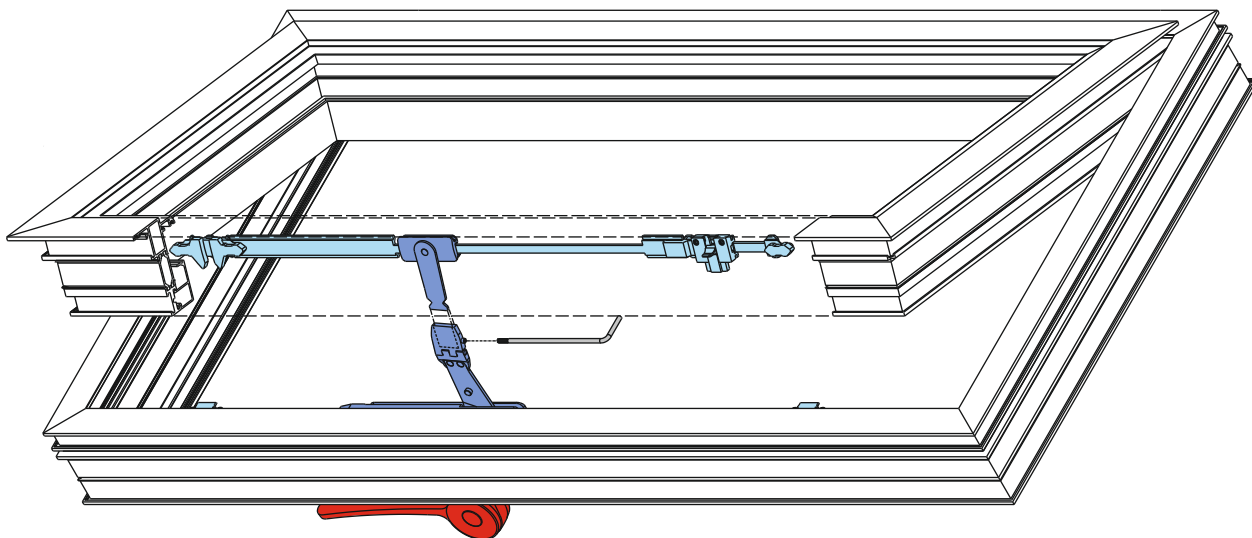

II

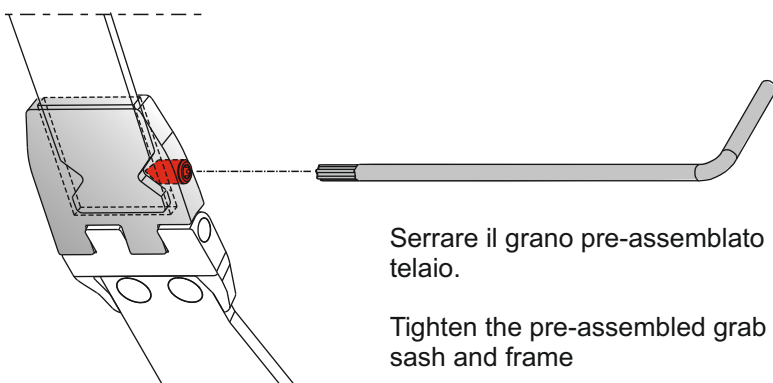
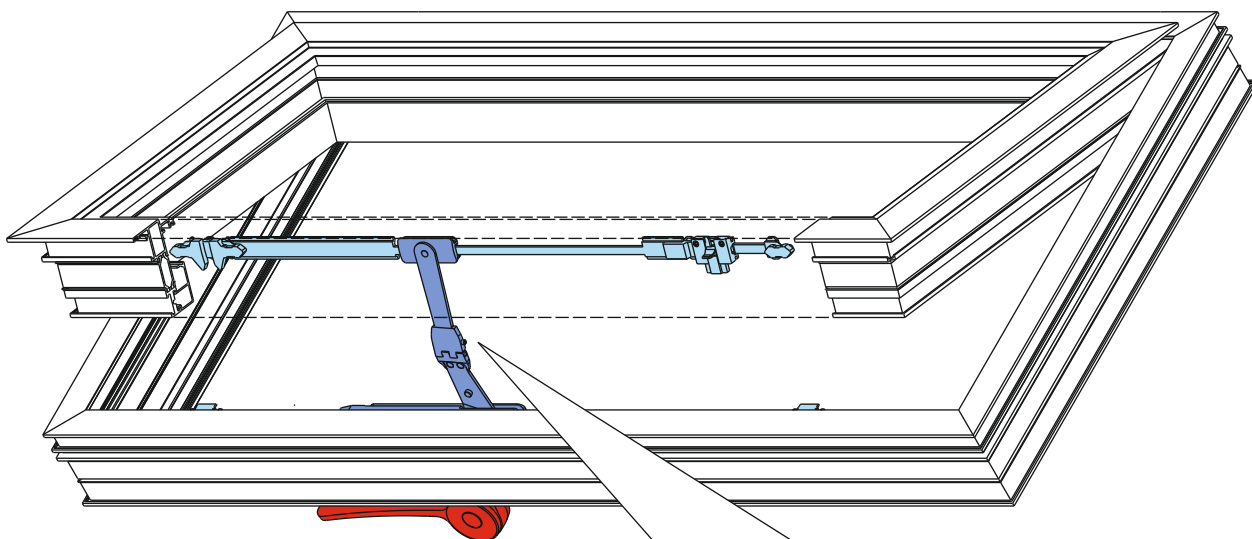

Serrare il grano pre-assemblato per completare il collegamento tra anta e telaio.

Tighten the pre-assembled grab screw to complete the connection between sash and frame